

 Service Instruction ENGINE COMPONENTS, INC.	S.I. No.: 92-9-9
	Page: 1 of 2
Title: CYLINDER BARREL CHOKE SPECIFICATIONS <i>Technical Portions are FAA DER Approved.</i>	Issued: 09/22/92 Revision: 1 (11/07/05)

BACKGROUND

From the time the air cooled internal combustion engine was introduced, one fact has remained – combustion releases heat and this heat is dissipated as follows:

- 25-30% Converted into useful power
- 40-45% Carried out with the exhaust gases
- 5-10% Removed by the oil
- 15-20% Escapes through the cylinder head and barrel walls to be carried away by the cooling air.

Heat dissipating through the cylinders creates unusual expansion problems. Most particularly the barrel expands disproportionately at the head and where the combustion occurs. In order for the bore to be straight during operations, the head end must be made smaller when the barrel is cold. This size reduction is referred to as “choke”.

PRESENT AFTERMARKET

Each manufacturer and repair station has its own FAA approved barrel contours, some with virtually no choke and others with geometry that is unusual or ill defined. Since 1951, Engine Components, Inc. (ECi®) has continually revised its data to assure that it is supplying the very best product possible for field operations. These choke specifications are attached for information only.



ENGINE COMPONENTS, INC.

Service Instruction No.92-9-9, Revision: 1 (11/07/05)

CYLINDER BARREL CHOKE SPECIFICATIONS

Page 2 of 2

	AIR-COOLED ENGINE TYPE	EC CLASS	"A" DIM.	"B" DIM.	"C" DIM.	"D" DIM.	"E" DIA.	STANDARD		MAX SERVICEABLE STANDARD		ALLOWABLE TAPER FROM "F" TO "G"	AMOUNT OF CHOKE FROM:			TOTAL CHOKE "G" TO "J"	MAX OVERSIZE BEFORE PLATE	FINISHED OVERSIZES			
								"F" DIA.	CIRCULARITY T.I.R.	"F" DIA.	CIRCULARITY T.I.R.		"G" TO "H"	"H" TO "J"	"G" TO "J"			PLAIN STEEL	NITRIDED STEEL	THRU HARDEN	CERMINIL™ PROCESS
LYCOMING, ECI SUPERIOR	235	1	6.063	5.375	4.125	1.020	4.3770/4.3745	4.3765/4.3745	.0025	4.380	.004	-.000/- .0015	-.001/- .003	-.001/- .003	-.002/- .006	N/A	.010, .020	.010, .020	.010, .020	.010, .020	NONE
	0-290, 0-435	2, 3, 39	6.250	5.500	4.250	1.020	4.8780/4.8745	4.8775/4.8745	.003	4.879	.004	-.000/- .0015	-.001/- .003	-.001/- .003	-.002/- .006						
	GO-435	17, 18, 19	6.250	5.500	4.250	1.020	4.8780/4.8745	4.8775/4.8745	.003	4.879	.004	-.000/- .001	-.001/- .003	-.003/- .006	-.004/- .009						
	320, 480	4, 5, 6, 7, 8, 21, 22, 23, 41	6.250	5.500	4.250	1.020	5.1280/5.1245	5.1275/5.1245	.003	5.131	.004	-.000/- .001	-.001/- .003	-.003/- .006	-.004/- .009						
	340	9	6.375	5.625	4.375	1.020	5.1280/5.1245	5.1275/5.1245	.003	5.131	.004	-.000/- .001	-.001/- .003	-.003/- .006	-.004/- .009						
	360, 540, 541, 720	10, 11, 12, 13, 14, 15, 16, 24, 25, 26, 27, 28, 29, 30, 31, 32, 33, 35, 36, 38, 40, 42, 43, 44, 46, 47, 48	6.813	6.063	4.813	1.020	5.1280/5.1245	5.1275/5.1245	.003	5.131	.004	-.000/- .001	-.001/- .003	-.003/- .006	-.004/- .009						
CONTINENTAL, ECI SUPERIOR	A65, A75, A80	60	6.188	5.438	4.188	1.200	3.8780/3.8750	3.8770/3.8750	.002	3.882	.004	-.000/- .0015	-.001/- .003	-.001/- .003	-.002/- .006	.030	.005, .010, .015	.005, .010, .015	.005, .010, .015	.005, .010, .015	NONE
	C75, C85, C90, O200	61	6.188	5.438	4.188	1.350	4.0650/4.0620	4.0640/4.0620	.002	4.069	.004	-.000/- .0015	-.001/- .003	-.001/- .003	-.002/- .006						
	C125, C145, O300, GO300	61, 63	6.188	5.438	4.188	1.350	4.0650/4.0620	4.0640/4.0620	.002	4.069	.004	-.000/- .0015	-.001/- .003	-.001/- .003	-.002/- .006						
	I0360, TSIO360, LTSIO360	66	6.375	5.625	4.375	1.438	4.4400/4.4370	4.4390/4.4370	.002	4.442	.004	-.000/- .001	-.001/- .003	-.003/- .006	-.004/- .009						
	E165, E185, E225, 470	64, 67, 68, 70	6.500	5.750	4.500	1.150	5.0040/5.0010	5.0030/5.0010	.002	5.006	.004	-.000/- .001	-.001/- .003	-.003/- .006	-.004/- .009						
	346, 520, 550	65, 71, 72, 73, 74, 75, 76	6.500	5.750	4.500	1.150	5.2540/5.2510	5.2530/5.2510	.002	5.256	.004	-.000/- .001	-.001/- .003	-.003/- .006	-.004/- .009						
	LIQUID-COOLED ENGINE TYPE	EC CLASS	"A" DIM.	"B" DIM.	"C" DIM.	"D" DIM.	"E" DIA.	STANDARD		MAX SERVICEABLE STANDARD		AMOUNT OF CHOKE FROM:			MAX OVERSIZE BEFORE PLATE	FINISHED OVERSIZES					
								"F" DIA.	CIRCULARITY T.I.R.	"F" DIA.	CIRCULARITY T.I.R.	"F" TO "G"	"F" TO "H"	"F" TO "J"		PLAIN STEEL	NITRIDED STEEL	THRU HARDEN	CERMINIL™		
CONTINENTAL	TSIOL-520, TSIOL-550	77	6.500	5.750	4.500	1.150	5.2540/5.2510	5.2530/5.2510	.002	5.256	.003	-.001/ .001	.001/ .003	.004/ .006	.020	N/A	N/A	N/A	NONE		

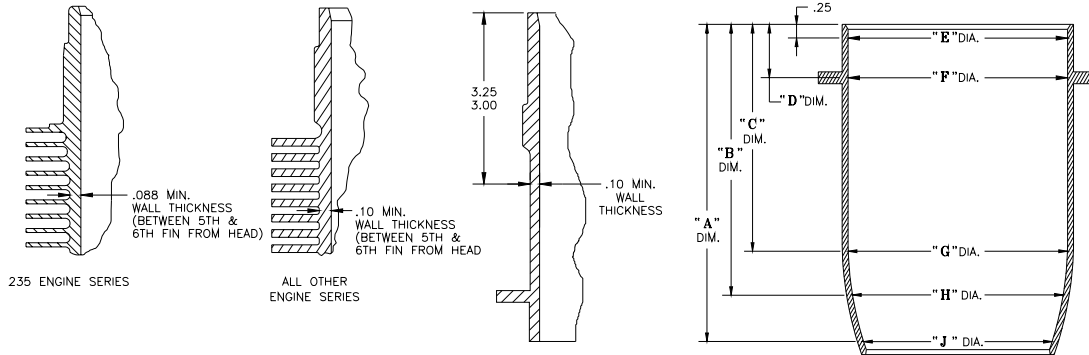

AIR-COOLED BARRELS

LIQUID-COOLED BARRELS